



QSS-2611

COMPACT HIGH PERFORMANCE MINILAB



NORITSU



QSS-2611 SYSTEM

QSS-2611 PRINTER-PAPER PROCESSOR: COMPACT HIGH PERFORMANCE MINILAB

The QSS-2611 printer-paper processor is an ideal solution for businesses looking to add versatility or expand existing capabilities.

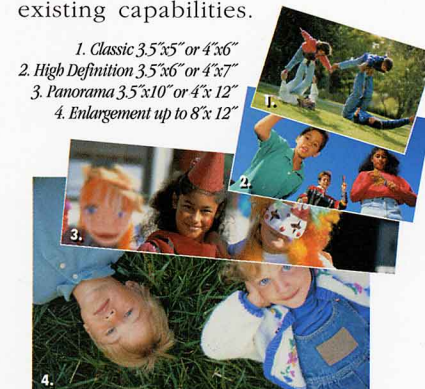

The QSS-2611 automatically prints intermixed negatives from IX240 or 135 film in a single pass.

Engineered to provide the capabilities of much larger machines, the QSS-2611 produces over 900 3.5" x 5" prints per hour, processes prints up to 8" x 12", prints 135 full and panorama,



Dual Paper Magazines.

110, 126, and 120 film formats, and is IX240 capable. In addition, the QSS-2611 can be factory ordered with either RA-4 or SM chemistry and is available with either single or dual paper magazines.

OPTIONAL 120 ZOOM LENS

A 120 zoom lens compatible with the complete range of 120 negatives is available for use with the QSS-2611. The optional lens eliminates the need to change lenses for each negative

size, which reduces operator workload, permits processing without significant interruption, and, ultimately, increases overall processing capabilities.

THE LATEST IN DIGITAL PRINTING TECHNOLOGY

The 2611 includes an in-line 4" Vacuum Fluorescent Print (VFP) — the latest in digital printing technology — as a standard feature. The VFP-4 automatically produces index prints on silver halide paper as the last print from both 135 and IX240 film. When, for example, a 25 exposure roll is processed, the 2611 outputs the index



The built-in VF Printer creates index prints on photographic paper, saving time and material costs.

print as the 26th print. The VFP-4 also can print images up to 4" x 7".

An optional 8" VFP is available for use with the QSS-2611. The VFP-8 provides all the functionality of the VFP-4 and outputs digital prints up to

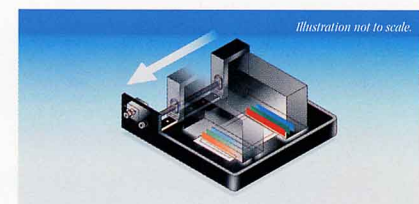

The Vacuum Fluorescent Printer (VFP) cuts production costs and speeds turnaround time.

8" x 10" with 290 dpi onto silver halide paper. To further expand your digital printing capabilities, an optional DCP-760 digital printer can be added to the QSS-2611 to create speciality prints ranging from sticker prints to calendars.

For on-site photo processors looking to give their customers the widest possible range of digital speciality prints, Noritsu's EZ Mall digital photo processing software is the ideal solution. EZ Mall was designed specifically for use with QSS systems and gives operators an easy-to-use application for manipulating images and creating digital prints from a PC attached to the 2611.



SIMPLIFIED OPERATION

The easy to use, fully automatic QSS-2611 includes several design features that maximize operator productivity. A 10" digital color monitor



The digital monitor displays positive images of the negatives as well as error messages and instructions.

displays positive images of negatives in 4, 6, and 40 frame modes, as well as operator instructions. A built-in densitometer makes corrections for easy

Large digital color monitor displays scanned and digitized images.

Operator friendly keyboard makes operation and data entry quick & easy.

3.5" floppy disk drive for data recovery and storage.

Viewer displays negative position.

Self-cleaning turn rack simplifies maintenance.



Dual Paper Magazine

Sheet printing system cuts paper waste.

Available in either RA-4 or SM chemistry.

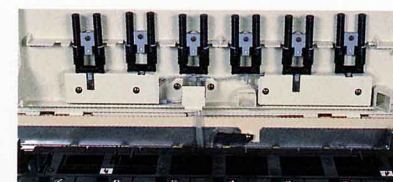

Self Cleaning Upper Turn Racks.

operator set-up, resulting in high quality prints. Self cleaning upper turn racks and automatic water replenishment reduce operator workload and minimize start-up/close-down responsibilities. The standard non-resettable counter helps monitor production.

NORITSU SUPPORT

Noritsu founded the one hour photo industry in North America 20 years ago and continues to lead the industry. We have established a tradition of technical innovation and customer satisfaction that sets the standard for the industry.

We provide in-depth assistance including complete installation of equipment, comprehensive training, ongoing post-installation service and support, and continual news updates on products, accessories, trade shows and other information via newsletter, web site and other materials. We also offer



the world's broadest range of supplies and accessories to complement and enhance your photofinishing system.



The compact QSF-V30 film processor works in conjunction with the QSS-2611 processing up to 26 rolls of 24 exposure 135 film per hour or up to 26 rolls of 25 exposure IX240 film per hour.

NORITSU

QSS-2611 SPECIFICATIONS

Dimensions.....	Single Paper Magazine: 73"(L) x 30"(W) x 52"(H) Dual Paper Magazine: 85"(L) x 30"(W) x 52"(H)
Power Requirements.....	1Ø-2w, AC 200-240V, 50/60Hz, 24-26A 3Ø-3w, AC 200-240V, 50/60Hz, 16-17A
Dry to Dry Time.....	RA: 3 min. / 48 sec. SM: 3 min. / 10 sec.
Operational Weight.....	RA: 1,121 lbs. Total; 848 lbs. (Body) + 273 lbs. (Solutions) or SM: 1,020 lbs. Total; 899 lbs. (Body) + 121 lbs. (Solutions)
Film Formats.....	135F/P/H, IX240, 110, 126, 120
Paper Width.....	8" max. / 3.25" min.
Paper Feed Length.....	12" max. / 4.6" min.
Paper Roll Length.....	575 feet
Maximum Advance Length.....	12"
Temperature.....	64°-86°F
Relative Humidity.....	30-75%

QSS-2611 REPEAT PRINT CAPACITY

FILM TYPE	PAPER WIDTH	ADVANCE	PRINTS PER HOUR RA	PRINTS PER HOUR SM
135F	3.5"	5"	1,346	1,346
135F	4"	6"	1,150	1,150
135F	5"	7"	500	500
135F	6"	8.5"	419	419
135F	8"	10"	361	361

QSS-2611 APPROXIMATE PRODUCTION CAPACITY

FILM TYPE	PAPER WIDTH	ADVANCE	PRINTS/HOUR PJP (4 FRAME DISPLAY) RA	PRINTS/HOUR SM
135F	3.5"	5"	936	936
135F	4"	6"	840	840
135F	5"	7"	448	448
IX240	C/H/P INTERMIXED		688*	688*

DIAGRAMS

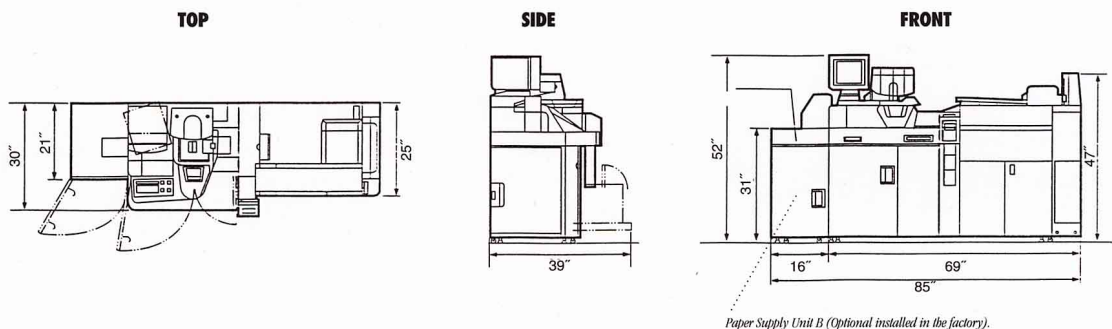

Specifications subject to change without notice. Printer-Paper Processor capacities are based on continuous printing of a negative under normal exposure. The capacity of the machine varies with the process chemicals used, condition of negatives, print sizes, etc. *The capacity includes Index Prints made on 3.5" width paper using the VF printer unit.

QSS, QSF, **EZ MAIL** and **INDEXPRINT** are trademarks of Noritsu.

• **Noritsu America Corporation:** 6900 Noritsu Avenue, Buena Park, California 90620-1372 (714) 521-9040 • **Western Regional Office:** 6950 Noritsu Avenue, Buena Park, California 90620-1311 (714) 521-9040 • **Eastern Regional Office:** 336 Route 46 East, Fairfield, New Jersey 07004-2429 (973) 808-9898 • **Midwest Regional Office:** 755 Tollgate Road, Elgin, Illinois 60123-9334 (847) 888-8000 • **Southern Regional Office:** 2989 North Stemmons Freeway, Dallas, Texas 75247-6193 (214) 631-2400 • **Government Sales Office:** 8000 Towers Crescent Drive, Suite 1350, Tysons Corner, Virginia 22182-2700 (703) 821-0007 • **Subsidiary; Noritsu Canada Ltd.:** 2680 Argentia Road, Mississauga, Ontario, Canada, L5N 5V4 (905) 567-8982 • **Subsidiary; Noritsu de México S.A. de C.V., Plaza Mayorazgo de Luyando No. 7, Col. Xoco, Delegación Benito Juárez, C.P. 03330 México, D.F. (52) 5-601-0429** • **Web Site:** www.noritsu.com

